

# MAIMIN®

## *Straight Knife Cutting Machine with Flexi-Band Sharpener (Model A)*

SABRE 900  
SABRE 800  
SABRE 700

## Instructions and Parts List

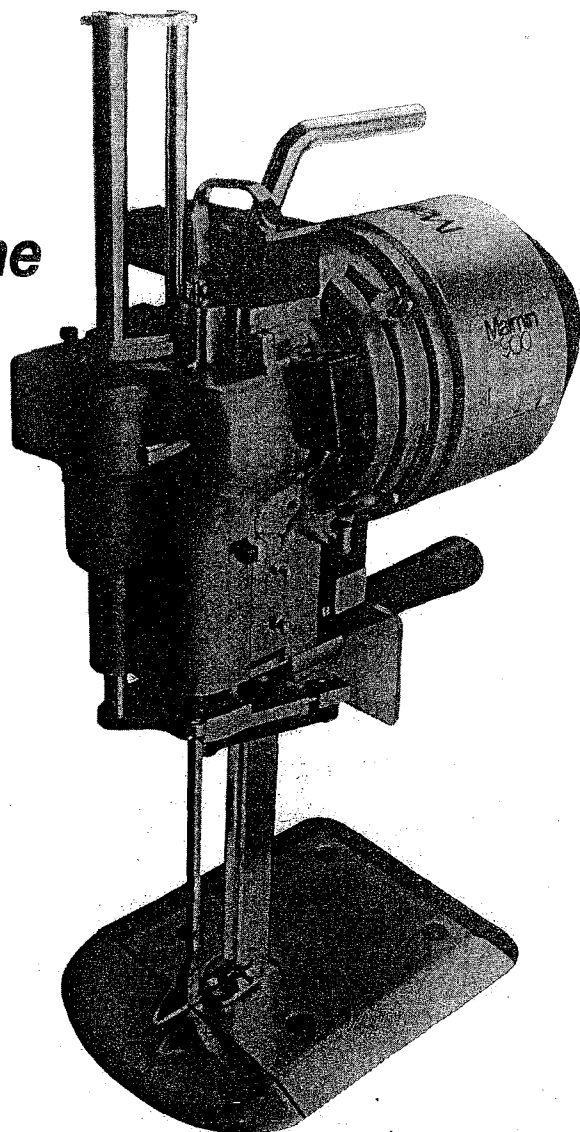

© 1982 H. MAIMIN CO., INC.

### SAFETY INSTRUCTIONS

1. BE SURE MACHINE IS PROPERLY GROUNDED. The cutting machine should be grounded while in use to protect the operator from electrical shock. Use a Maimin Grounded Connector (#458B, or #458A for 3 phase machine).
2. USE CORRECT ELECTRICAL WIRING
 

U.S.A. only	1 phase: Use AWG 16/3 SJ, SJT
	3 phase: Use AWG 16/4 SJ, SJT
INTERNATIONAL	1P + N + 1: Use 3x 1, 0 mm <sup>2</sup> CEE(2)61
	3P + 1: Use 4x 1, 0 mm <sup>2</sup> CEE(2)61
3. KEEP CUTTING AREA CLEAN. A cluttered table can cause accidents.
4. AVOID DANGEROUS ENVIRONMENT. Do not use machine in a damp or wet location. The work area should be well lit.
5. KEEP VISITORS AWAY. They should be kept at a safe distance from the cutting area.
6. STORE MACHINE PROPERLY. When not in use, the machine should be stored in a dry location.
7. MAINTAIN MACHINE WITH CARE. Keep machine clean and blade sharp for best and safest performance. Follow instructions for lubricating.
8. ALWAYS DISCONNECT MACHINE when not in use, before servicing, and when changing blades.
9. REMOVE KNIFE KEY AND WRENCHES. The knife key and other wrenches must be removed from machine before starting motor.
10. AVOID ACCIDENTAL STARTING. Disconnect electrical cord before carrying machine. Be sure switch is off before connecting cord.
11. KEEP GUARDS IN PLACE AND IN WORKING ORDER.
12. KEEP HANDS AWAY FROM CUTTING BLADE.

# I. DESCRIPTION

## 1.1 GENERAL

Your new Maimin Sabre straight knife machine is delivered ready for operation. It is merely necessary to connect it to an electrical outlet of the correct voltage, oil it, and then begin cutting. The straight knife machine can be used for cutting various types of materials from a few ply to the full capacity of the machine. However, for best results, it is recommended that the minimum height of the lay be no lower than the bottom of the cutting blade at its highest position. The Presserfoot Leg (Key No. A403) acts as a protective guard for the operator so that it should be down at all times. The Presserfoot should lie lightly on top of the lay when cutting in order to prevent the material from vibrating.

## 1.2 FLEXIBANDS AVAILABLE

Three different grits of "FlexiBands" are available for sharpening the blade:

- Coarse — For hard or coarse materials  
(Part 1450 — Box of 100)
- Medium — For fine woolens, synthetics and cottons  
(Part 1451 — Box of 100)
- Fine — For sheer fabrics, very soft materials  
(Part 1452 — Box of 100)

## 1.3 BLADES AVAILABLE

The blades come in three grades and in different shapes for cutting unusual or difficult materials. The three grades available are:

- ZK — High Speed Steel . . . Most popular blade as it wears well retaining its cutting edge for a long time.
- BK — Carbon Alloy Steel . . . A quality blade less durable than the ZK blade but less costly.
- TK — Treated High Speed Steel . . . Retains cutting edge very well. Used only for hard or abrasive materials such as fiberglass or heavy denim as it is very expensive.

See back cover for complete list of part numbers of blades according to size, grade, shape, and quantity.

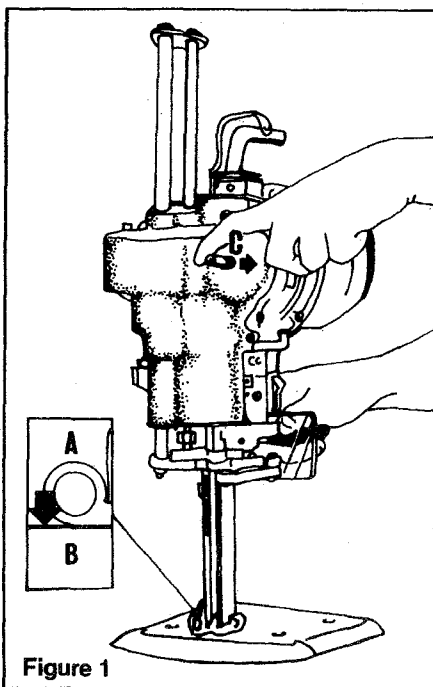

Figure 1

# II. OPERATION

## 2.1 UNPACKING A NEW MACHINE

During shipment oil may have flowed onto Pulley A303 which can cause sharpener to traverse slowly. Sharpener cycle time is 1.5 seconds. If longer, oil is causing Pulley to slip. To remove oil, disconnect power, remove Brake A342, wipe oil from Pulley and Crank A505. Replace Brake as described in paragraph 2-11.

## 2.2 TO START

Fill oil cup. Attach Connector A525 to Terminal Pins A523. Move switch A550 from "off" to "on" (USA) or "O" to "I" (International).

**Caution:** 3 phase motor must turn counter-clockwise when viewed from rear.

## 2.3 TO SHARPEN BLADE (Figure 1)

Machine should be clear of lay and Presserfoot "A" should be down on Baseplate "B." With motor running, move Trippler Handle "C" to right (facing sharpener) until it latches. Release it. Sharpener will automatically sharpen entire blade. Repeat if necessary.

## 2.4 TO CUT

Raise Presserfoot A402 above top of lay by pressing down on Presserfoot Handle A323 and lifting Presserfoot Lift A404. For Squeeze Trigger, pull Handle 480A towards machine Handle A549. Enter lay, and lower Presserfoot to top of lay by releasing Presserfoot Trigger. When making turns in lay, it is sometimes advisable to let Presserfoot ride freely on top of lay by pushing down on Presserfoot Handle. When machine is not in use, always lower Presserfoot to Baseplate. The Presserfoot Leg acts as a safety guard for the blade.

## 2.5 TO CHANGE FLEXIBANDS (Figures 2 and 3)

a) Figure 2: Push Block "A" to release right (upper) FlexiBand "B." Remove FlexiBand from Block and then from Drive Pulley "C."

b) Figure 3: Slip new FlexiBand "B" over Drive Pulley "C" and between Band Plate "D" and Blade "E." Push Block "A" forward and slide FlexiBand over it. Release Block "A."

c) Remove left (lower) FlexiBand, and install new one in same manner.

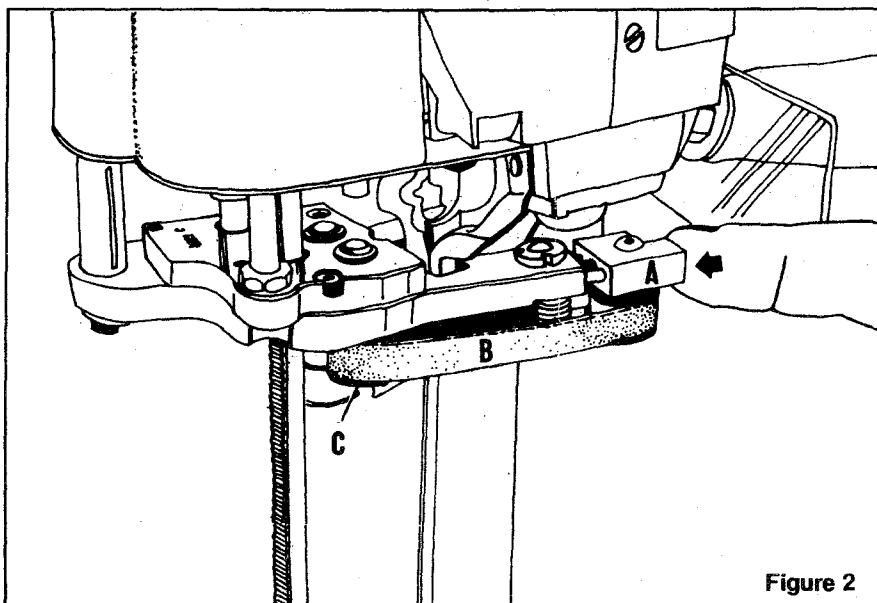

Figure 2

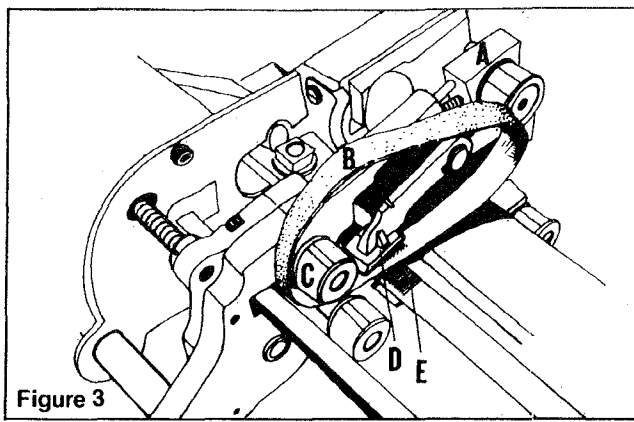

Figure 3

## 2.6 TO CHANGE BLADE (Figure 4)

- a) Disconnect power
- b) Lay machine on left side.
- c) Press and turn Thumbwheel "A" to move Blade to its lowest position.
- d) With Knife Key "B" turn Nut "C" counter-clockwise to unlock blade.
- e) Raise Presserfoot Leg and slide Blade "D" downwards and out.
- f) Clean Inserts "E" with slot cleaning tool or bottom corner of blade.
- g) Slide new Blade up against Knife Locking Bolt.
- h) Holding lower part of Blade, push it firmly *up* against Bolt and *back* against Inserts.
- i) Tighten Nut "C."

Note: Use only genuine Maimin Blades with "Cut-Out" and T-shaped slot in shank for optimum performance and safe operation.

*Always tighten Knife Locking Bolt and Nut before running machine* to prevent damage to Crosshead A510 and Gibbs A513. Do not run sharpener without blade in machine or sharpener will jam.

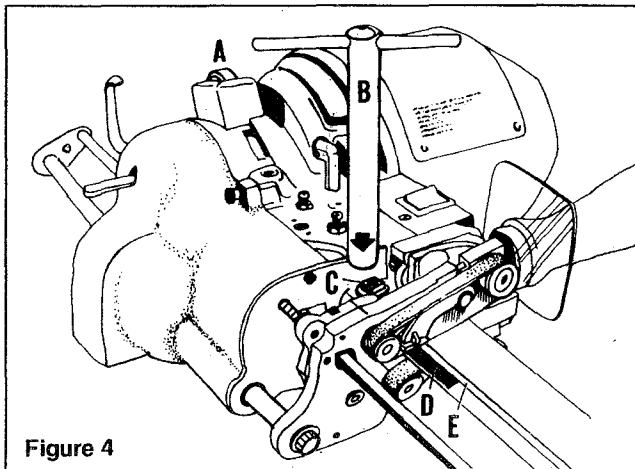

Figure 4

## 2.7 TO CHANGE BEVEL WIDTH ON BLADE (Figure 5)

- a) Run sharpener to lowest position, turn off motor, disconnect power.
- b) Loosen Screw "A."
- c) Insert Bevel Adjusting Tool "B" into Washer "C" and rotate Washer to increase or decrease blade bevel width. Note

arrow on washer and edge width indicator on Band Plate Carrier (A374).

d) Tighten Screw "A."

e) Bevel on opposite side is adjusted in same manner.

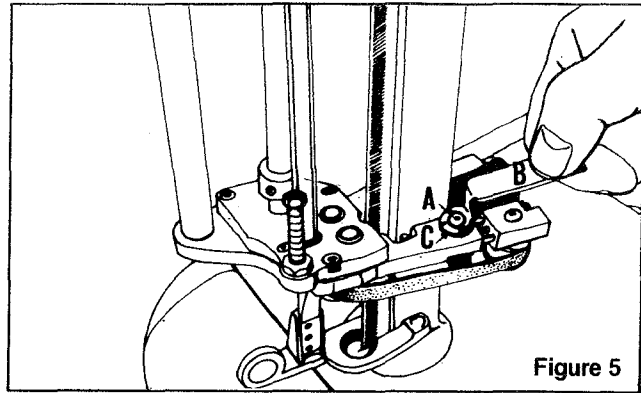

Figure 5

## 2.8 MAINTENANCE SCHEDULE

- a) Daily: Fill oil cup (A547). Use either Maimin oil or quality "30 weight" oil (I.S.O. viscosity grade 320).
- b) Weekly:
  - (1) Sharpener — run to lowest position, turn off motor, and blow out lint and dust with compressed air.
  - (2) Motor — run motor, and point stream of compressed air into back of motor and side of front housing by fan to eject lint and dust.
- c) Every 500 hours of operation: Remove motor cover and, with compressed air, blow lint and dust from motor coils and armature.

## 2.9 TO REMOVE SHARPENER FROM MACHINE (Figure 6)

- a) Run sharpener to lowest position, turn off motor and disconnect power.
- b) Figure 6: Disengage Tripper Handle "A" by inserting handle of Knife Key "B" through hole in lower cover and pressing upwards until Tripper Handle snaps back to its "off" position.
- c) Remove Screw A390 holding Clamp Plate A394 against Band Plate Guide A393 and remove Guide and Plate.
- d) With 3/8" wrench remove 2 Nuts A344 and 2 Washers A343 holding Brake A342, and remove Brake.
- e) Remove Screw A316 holding Shafts Cover A315, and lift off Cover.
- f) Remove 3 Nuts A328 and 1 Nut 510B (at lower left rear corner of sharpener) which hold Drive Housing A327.
- g) Pull sharpener forward gently to remove.

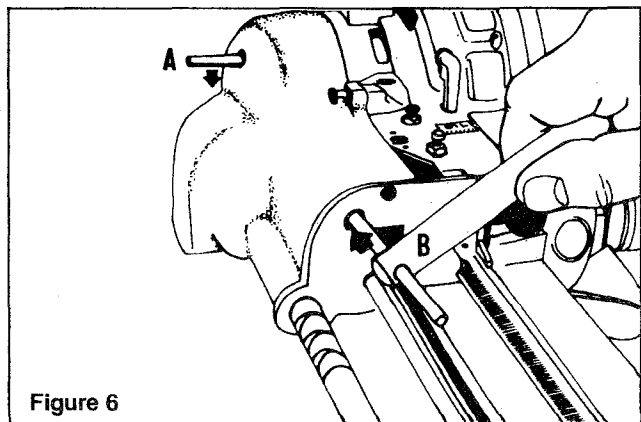

Figure 6

## 2.10 TO ATTACH SHARPENER TO MACHINE

- Wipe oil from outer diameter of Crank A505 and Pulley A303.
- Place sharpener onto 3 mounting Screws A521 on Front Housing.
- Add and tighten 3 Nuts A328 and Nut 510B on back of sharpener.
- Add Band Plate Guide A393 and Clamp Plate A394.
- Hold Guide against Standard A564 and tighten Screw A390.
- Lower Presserfoot Leg to Baseplate, connect power, and run sharpener to its top position. Disconnect power.
- Add Shafts Cover A315.

## 2.11 TO SET POSITION OF BRAKE A342

### (Figure 7)

- Wipe clean inside surface of Brake and fit it into position over mounting Screws on back of Sharpener.
- Add Washers A343 and Nuts A344 loosely.
- Slide Brake in until it touches Pulley A303. Hold it in this position and tighten the two Nuts A344.
- Connect power, run sharpener once.
- Fig. 7: Check clearance between lower Cover "A" and top of Gear Case "B." Maximum distance is  $25/32"$  (2 cm) when Brake is properly installed. If distance is greater, reset Brake as Presserfoot Leg A403 will not operate. FlexiBands A386 must not touch Blade A574.

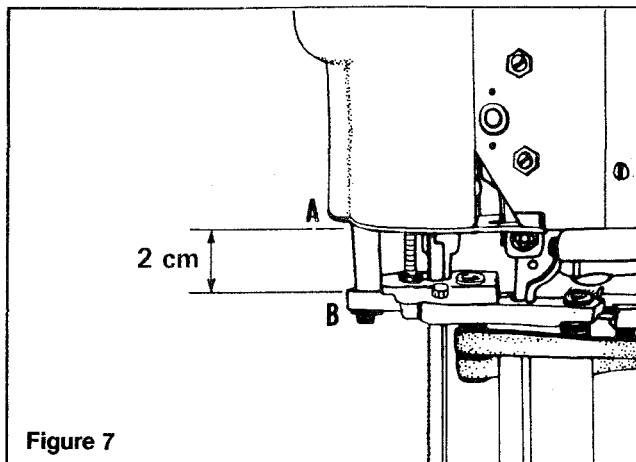

Figure 7

## 2.12 TO REMOVE MOTOR COVER A579

### (Figure 8)

Disconnect Power. Loosen the 3 Screws A580, and slide Motor Cover off.

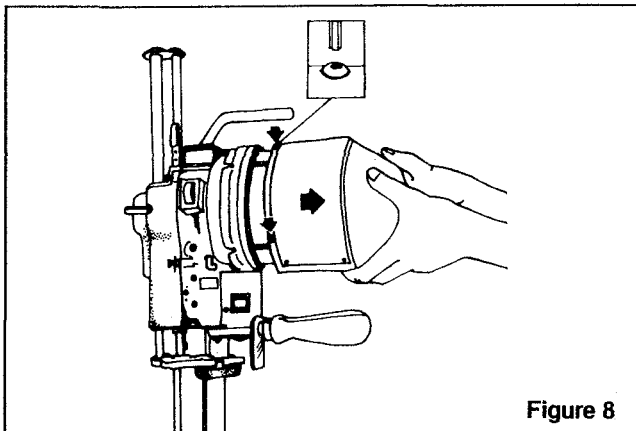

Figure 8

## III. TROUBLE SHOOTING GUIDE

### 3.1 MACHINE TROUBLE SHOOTING

#### Symptom

#### Possible Cause

- |  |  |
|--|--|
| 1. Bottom corner of blade breaks.                    | <ol style="list-style-type: none"> <li>Inserts (A558) badly worn.</li> <li>Knife strikes throat plate. If cutting hard materials, use wide slot throat plate.</li> </ol>   |
| 2. Motor slow in reaching full speed.                | <ol style="list-style-type: none"> <li>Low voltage or wrong voltage.</li> <li>Three phase:               <ol style="list-style-type: none"> <li>Fuse out on one phase.</li> <li>Ground wire incorrectly connected to machine.</li> </ol> </li> </ol>                       |
| 3. Motor binds at one spot.                          | <ol style="list-style-type: none"> <li>Crosshead (A510) and Gibbs (A513) tight.</li> <li>Standard (A564) not in alignment with Crosshead (A510).</li> <li>Standard (A564) bent.</li> </ol>   |
| 4. Motor becomes hot.                                | <ol style="list-style-type: none"> <li>Lint and dust inside Motor Cover (A579).</li> <li>Three phase: one phase not working.</li> </ol>  |
| 5. Motor rotates wrong way.                          | <ol style="list-style-type: none"> <li>Three phase: Wiring incorrect. Change any two wires in Terminal Block (A522) or Connector (A525).</li> </ol>  |
| 6. Motor does not start.                             | <ol style="list-style-type: none"> <li>Connector (A525) not firmly attached to Terminal Pins (A523).</li> <li>Switch (A550) defective.</li> <li>Relay (A540) and/or Capacitor (A543) defective.</li> </ol>   |
| 7. Terminal Block and/or Connector becomes very hot. | <ol style="list-style-type: none"> <li>Inserts in Connector (A525) worn. Change Connector.</li> <li>Terminal Pins (A523) worn.</li> </ol>  |
| 8. Machine does not roll freely on table.            | <ol style="list-style-type: none"> <li>Rollers in Roller Carrier (A562) packed with dirt. Clean but do not oil.</li> <li>Surface of cutting table not smooth.</li> <li>Cushions (A561) in Roller Carriers compressed causing Baseplate (A560) to drag on table.</li> </ol> |

## 3.2 SHARPENER TROUBLE SHOOTING

Symptom	Possible Cause
1. No bevel on one side of blade.	a) Idler Pulley (A396) needs oil. b) Broken Torsion Spring (A382, A388). c) Band Plates (A381, A387) do not rotate freely. d) Bands do not cross due to interference of Band Plates (A381, A387).
2. Bevel not high enough on blade.	a) Cam (A515, A516) out of position.
3. Sharpener runs but bands do not rotate.	a) Square Shaft Gear (A336) broken. b) Retaining Ring (A338) missing. c) Clamp (A364) out of position. d) Cluster Gear (A332) broken.
4. Sharpener does not run but bands rotate.	a) Keeper Plate (A334) loose. b) Boat (A333) worn.
5. Sharpener does not run and bands do not rotate.	a) Presserfoot Leg (A403) not down completely. b) Oil on Crank (A505) and/or Pulley (A303). c) Retaining Ring (A320) missing. d) Cluster Gear (A332) broken. e) Worm (A311) broken.
6. Band cut off by blade.	a) Band Plate (A387) defective.
7. Block (A397) falls off during band changing.	a) Retaining Ring (A398) missing.
8. Block (A397) pivots, twisting band.	a) Stud (A383) broken.
9. Sharpener runs slowly.	a) Oil on Crank (A505) and/or Pulley (A303). b) Band Plate Guide (A393) too tight against Standard (A564).
10. Sharpener overruns top position.	a) Brake (A342) too far from Pulley (A303). b) Screw (A363) too low.
11. Sharpener runs continuously.	a) Screw (A363) too low — less than 1" above Gear Case (A367). b) Screw (A363) missing. c) Retaining Ring (A345) missing. d) Spring (A341) broken.
12. Sharpener runs only when tripper handle is held.	a) Spring (A357) broken. b) Spring Pin (A359, A313) broken.
13. Sharpener jams.	a) Sharpener run without knife in machine. b) Boat (A333) broken. c) Diamond Shaft (A356) bent.
14. Presserfoot Leg (A403) does not move freely.	a) Sharpener not at top position. b) Dirt or oil in Leg Guide (A354). c) Brake (A342) too close to Pulley.
15. Presserfoot Leg does not hold.	a) Lock (A330) loose on Shaft (A325). b) Trigger Spring (A322) broken.
16. Safety not working.	a) Leg Guide (A354) broken. b) Safety Pin (A347) missing. c) Screw and Nut (327A) loose or missing.

# MODEL A SHARPENER

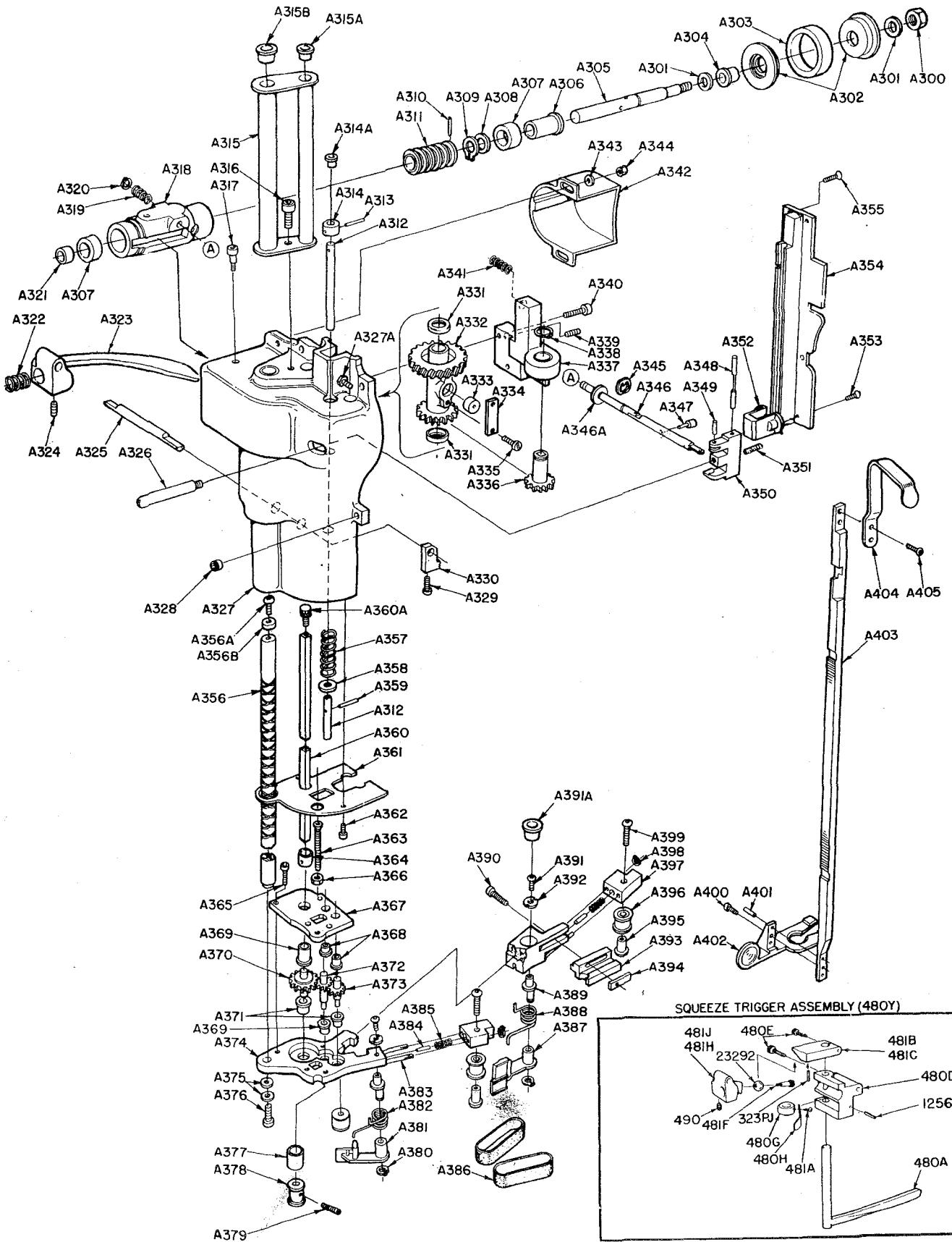

# PARTS LIST 1

KEY NO.	PART NO.	DESCRIPTION	KEY NO.	PART NO.	DESCRIPTION
A300	838N	Nut, 1/4-20 Hex	A360A	23277	Screw, 6 x 3/8 Knurled Nylon
A301	1499D	Washer, 1/4 x 9/16 x 3/64	A361	23244	Cover
A302	1498A	Clamp	A362	23226	Screw, 6 x 1/4 Socket Hd. Cap (2)
A303	1498	Pulley only	A363	23290	Screw, 10 x 1-1/2 Fillister Hd.
A304	23235	Bushing	A364	23212	Clamp w/23263
A305	23196	Worm Shaft		23263	Screw, 10 x 1/2 Slot Set Flat Pt.
A306	23231	Bearing, flanged .314 x .439 x 3/4	A365	824T	Screw, 6 x 3/8 Socket Cap (4)
A307	23232	End Cap	A366	510B	Nut, 10-32 Hex
A308	839W	Washer, .32 x 1/2 x 1/32	A367	23275	Gear Case with Bushings
A309	23234	Retaining Ring, 5100-31	A368	23086	Bearing, flanged .252 x .377 x 1/4
A310	23066	Spring Pin, 7/64 x 1/2	A369	23091A	Bearing, flanged .252 x .377 x 1/2
A311	23067	Worm	A370	23210	Drive Gear
A312	23036	Push Rod	A371	23086	Bearing, flanged .252 x .377 x 1/4
A313	23267	Spring Pin, 1/16 x 3/8	A372	23208	Driven Gear, left
A314	23005	Cam	A373	23209	Driven Gear, right
A314A	402BK	Tapered Plug #12	A374	23276	Band Plate Carrier w/Bushings
A315	23229A	Shafts Cover, 5" — 8"	A375	23261	Washer, 3/16 x 1/2 x 3/64
	23229B	Shafts Cover, 9"	A376	23084	Screw, 10 x 1/2 Socket Hd. Cap
	23229C	Shafts Cover, 11"	A377	23098	Rubber Tire (2)
	23229D	Shafts Cover, 14"	A378	23099	Drive Pulley (2)
A315A	402BF	Tapered Plug #9	A379	23097	Screw, 4 x 1/8 Soc. Set Flat Pt. (2)
A315B	402BJ	Tapered Plug #16	A380	23227	Retaining Ring 5100-25 (2)
A316	23056	Screw, 1/4 x 1/2 Socket Cap	A381	23165	Band Plate, right
A317	481F	Screw, 1/4 x 3/8 Shoulder (2)	A382	23110	Spring, Torsion, right
A318	23192	Cartridge w/Worm & Pulley	A383	23115	Stud, 1/8 x 1-1/8 (4)
	23193	Cartridge only	A384	23116	Spring Pin, 3/32 x 1/4 (2)
A319	23017	Spring	A385	23117	Spring (2)
A320	23219	Retaining Ring, 5555-23	A386	1450	FlexiBand, Coarse — 100/box
A321	23233	Bearing, .314 x .44 x 1/2		1451	FlexiBand, Medium — 100/box
A322	492	Trigger Spring		1452	FlexiBand, Fine — 100/box
A323	23047	Presserfoot Handle	A387	23164	Band Plate, left
A324	490	Screw, 5/16 x 3/8 Set	A388	23109	Spring, Torsion, left
A325	23049	Shaft	A389	23223	Eccentric Stud (2)
A326	23053	Tripper Handle	A390	23019	Screw, 6 x 5/8 Socket Cap
A327	23274	Drive Housing with Bushings	A391	23122	Screw, 6 x 1/4 Button Hd (2)
A327A	510A	Screw, 10 x 1/2 Socket Set Cup	A391A	402BH	Tapered Plug #14
	510B	Nut, 10-32 Hex	A392	23225	Washer (2)
A328	23252	Nut, 10-32 Socket (3)	A393	23250	Band Plate Guide, 5" — 8"
A329	23271	Screw, 8 x 5/8 Socket Hd. Cap		23272	Band Plate Guide, 9", 11"
A330	23050	Lock		23282	Band Plate Guide, 14"
A331	23243	Cup	A394	23249	Clamp Plate
A332	23189	Cluster Gear	A395	23114	Stud, Idler Pulley (2)
A333	23119	Boat	A396	23293	Pulley, Idler, w/Bushing (2)
A334	23120	Keeper Plate	A397	23111	Block (2)
A335	23259	Screw, 6 x 1/4 (2)	A398	23288	Retaining Ring, 5144-12 (2)
A336	23203	Square Shaft Gear	A399	23112	Screw, 8 x 1/2 Button Hd. (2)
A337	23273	Gear Block with Bushings	A400	23172	Screw, 4 x 1/4 Socket Hd. Cap
A338	1277	Retaining Ring, 5100-50	A401	23116	Spring Pin, 3/32 x 1/4 (2)
A339	23251	Screw, 10 x 3/4 Slot Set Flat Pt.	A402	23040	Presserfoot, 5" — 8"
A340	23019	Screw, 6 x 5/8 Socket Cap (2)		23040A	Presserfoot, 9" & 11"
A341	23031	Spring		23040B	Presserfoot, 14"
A342	23200	Brake	A403	23039A	Presserfoot Leg — 5"
A343	23007	Washer, 13/64 x 7/16 x 1/32 (2)		23039B	Presserfoot Leg — 6"
A344	510B	Nut, 10-32 Hex (2)		23039C	Presserfoot Leg — 7"
A345	23016	Retaining Ring, 5144-25		23039D	Presserfoot Leg — 8"
A346	23284	Link Assembly w/23283		23039E	Presserfoot Leg — 9"
A346A	23289	Washer, .257 x 9/16 x 1/32		23039F	Presserfoot Leg — 11"
A347	23283	Safety Pin		23039G	Presserfoot Leg — 14"
A348	23011	Pin	A404	824	Presserfoot Lift
A349	23013	Spring Pin, 3/32 x 5/16	A405	23122	Screw, 6 x 1/4 Button Hd. (2)
A350	23190	Tripper			SQUEEZE TRIGGER ASSEMBLY
A351	23054	Screw, 6 x 1/8 Socket Set Cup		323PJ	Pin
A352	23205	Leg Keeper		480A	Handle Assembly
A353	23258	Screw, 4 x 5/16 (2)		480D	Bracket
A354	23207	Leg Guide		480E	Screw, 10 x 5/8 Socket Cap
A355	23122	Screw, 6 x 1/4 Button Hd. Socket Cap (4)		480G	Collar w/481A and 480H
A356	23093A-W	Diamond Shaft Assy (give size & stroke)		480H	Spring
A356A	23286	Screw, 10 x 1/2 Button Hd. Soc. Cap		480Y	Squeeze Trigger Assy w/480D and 481J
		11" & 14" Machines Only		481A	Screw, 6 x 1/8 Round Hd.
A356B	23287	Washer, Nylon, .191 x 17/32 x 3/16		481B	Cam w/ 480E and 323PJ
		11" & 14" Machines Only		481C	Cam
A357	23008	Spring		481J	Presserfoot Lever w/490
A358	23007	Washer, 13/64 x 7/16 x 1/32		481H	Presserfoot Lever
A359	23267	Spring Pin, 1/16 x 3/8		481F	Screw, 1/4 x 3/8 Shoulder
A360	23211A	Square Shaft, 5" — 8"		490	Screw, 5/16 x 3/8 Set
	23211B	Square Shaft, 9"		1256	Spring Pin, 3/32 x 1/2
	23211C	Square Shaft, 11"		23292	Ball, 5/8
	23211D	Square Shaft, 14"			

257  
9/16  
30

Always Give Machine **SERIAL NUMBER** When Ordering Parts.  
Order By **PART NUMBER** — Not Key Number

# SABRE 800 AND 900 MOTORS WITH STANDARD ASSEMBLIES

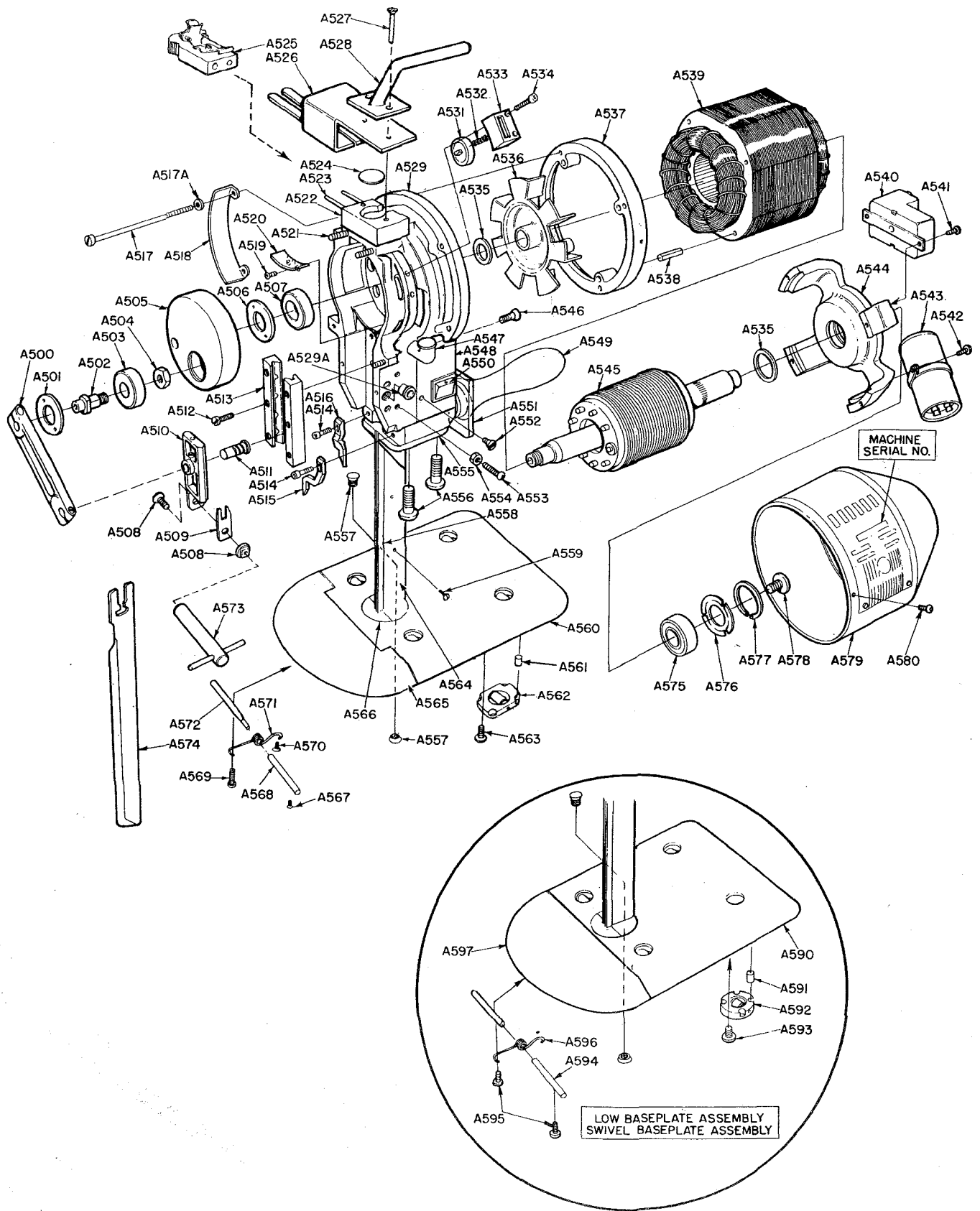



# PARTS LIST 2

KEY NO.	PART NO.		DESCRIPTION	KEY NO.	PART NO.		DESCRIPTION
	1	3			1	3	
A500	412A	412A	Connecting Rod — H	A547	402BD	402BD	Oil Cup
	412B	412B	Connecting Rod — M	A548	466E	466E	Cover, Switch, Sabre 800 (except USA-120V)
	412C	412C	Connecting Rod — L		466B	—	Cover, Switch, Sabre 900 & Sabre 800 (USA-120V)
	412D	412D	Connecting Rod — LI	A549	464B	464B	Tapered Handle only
A501	413W	413W	Bearing Lock		464P	464P	Curved Handle w/Bushing
A502	415	415	Crank Pin	A550	442G	442G	Switch, Sabre 800 (except USA-120V)
A503	414	414	Crank Bearing		443	—	Switch, Sabre 900 & Sabre 800 (USA-120V)
A504	415N	415N	Crank Nut	A551	464R	464R	Shield
A505	413BX	413LX	Crank w/413W, 414, 415-H	A552	818S	818S	Screw, 6 x 1/4 Flat Hd.
	413CX	413MX	Crank w/413W, 414, 415-M	A553	410	410	Screw, 8 x 1/2 Fillister Hd. (2)
	413DX	413NX	Crank w/413W, 414, 415-L	A554	410N	410N	Nut (2)
	413EX	413RX	Crank w/413W, 414, 415-LI	A555	464C	464C	Handle Block
	—	413VA	Screw, 1/4 x 1/4 Flat Pt. Soc. Set	A556	425	425	Bolt, 3/8 x 1 Button Hd. (3)
	—	413VB	Screw, 10 x 3/16 Flat Pt. Soc. Set	A557	435	435	Cone Lock & Nut
A506	404C	404C	Bearing Lock	A558	428A	428A	Insert for Standard — 9"
A507	403	403	Bearing #203		428B	428B	Insert for Standard — 8"
A508	416	416	Knife Bolt & Nut		428C	428C	Insert for Standard — 7"
A509	411A	411A	T-Slot Lock		428D	428D	Insert for Standard — 6"
A510	411	411	Crosshead w/411P		428E	428E	Insert for Standard — 5"
A511	411P	411P	Wrist Pin		428H	428H	Insert for Standard — 11"
A512	409A	409A	Screw, 8 x 3/4 Fillister Hd. (6)		428M	428M	Insert for Standard — 14"
A513	409C	409C	Gibbs, pair	A559	428S	428S	Insert Screw
A514	23226	23226	Screw, 6 x 1/4 Socket Hd. (2)	A560	429	429	Baseplate with Rollers & Lip
A515	23151	23151	Cam, Right	A561	436K	436K	Rubber Cushion
A516	23152	23152	Cam, Left	A562	436	436	Roller Carrier Assembly
A517	419Z	419Z	Bolt, 10 x 3-1/2, Sabre 800 (4)	A563	436S	436S	Screw, 10 x 5/32 M Hd.
	419ZB	419ZB	Bolt, 10 x 3-3/4, Sabre 900 (4)	A564	424A	424A	Standard — 9"
A517A	419R	419R	Washer, .200 x 3/8 x .036		424B	424B	Standard — 8"
A518	402W	402W	Windguard		424C	424C	Standard — 7"
A519	802S	802S	Screw, 6 x 3/16 Binding Hd. (2)		424D	424D	Standard — 6"
A520	402L	402L	Oil Guard		424E	424E	Standard — 5"
A521	23230	23230	Screw, 10 x 7/8 Flat Pt. Soc. Set (3)		424H	424H	Standard — 11"
A522	405	405A	Terminal Block with Pins		424M	424M	Standard — 14"
A523	406	406A	Terminal Pin (2,3)	A565	430	430	Lip
A524	405F	405B	Fibre Cover	A566	426A	426A	Throat Plate — 5" — 8"
A525	458B	458A	Current Connector		426B	426B	Throat Plate — 9"
A526	458K	458M	Ground Shield		426C	426C	Throat Plate, Wide Slot — 5" — 9"
A527	408A	—	Screw, 8 x 1-3/4 Flat Hd.		426E	426E	V Throat Plate — 5" — 8"
	—	408B	Screw, 8 x 2 Flat Hd.		426F	426F	V Throat Plate — 9" — 14"
A528	407D	407D	Top Handle		426V	426V	V Throat Plate w/Nest
A529	402CC	402CD	Front Housing w/23230 (3)		427	427	Screw, 10 x 7/16 Flat Hd.
A529A	402BG	402BG	Tapered Plug #7-S		427N	427N	Nest
A531	468J	468J	Thumbwheel w/Shaft	A567	436S	436S	Screw, 10 x 5/32 M Hd.
A532	468C	468C	Spring	A568	431B	431B	Shaft, Short
A533	468D	468D	Thumbwheel Support	A569	802S	802S	Screw, 6 x 3/16 Binding Hd.
	468A	468A	Thumbwheel Assembly	A570	802S	802S	Screw, 6 x 3/16 Binding Hd.
A534	468S	468S	Screw, 6 x 7/8 Socket Hd. (2)	A571	433B	433B	Spring, Lip, Small
A535	497P	497P	Support Washer	A572	431A	431A	Shaft, Long
A536	400J	400J	Fan	A573	457	457	Knife Key
A537	302QC	302QC	Adaptor Ring	A574	—	—	Blade (see back cover)
A538	302QD	302QD	Spring Pin, 5 x 20 mm (4)	A575	403	403	Bearing #203
A539	15097A	15202A	Stator, Sabre 800, 60 HZ*	A576	404D	404D	Loading Spring
	15211	15202A	Stator, Sabre 800, 50 HZ*	A577	404E	404E	Retaining Ring — 5008-156
	15222	—	Stator, Sabre 900, 60 HZ*	A578	404F	404F	Lock Screw
	15226	—	Stator, Sabre 900, 50 HZ*	A579	302QB	302QB	Motor Cover
A540	365G	—	Relay, Sabre 800, 692 — 120/60/1, 220/50/1, 110/50/1	A580	23122	23122	Screw, 6 x 1/4 Button Hd. (3)
	365E	—	Relay, Sabre 800, 703 — 220/60/1	A590	429B	429B	Low Baseplate with Rollers & Lip
	365D	—	Relay, Sabre 900, 716 — 60 HZ		440A	440A	Swivel Baseplate with Rollers & Lip
	365H	—	Relay, Sabre 900, 710 — 50 HZ	A591	436L	436L	Cushion, Small
	—	483	Voltage Change Panel, 50 HZ	A592	436E	436E	Roller Carrier, Low
A541	802S	—	Screw, 6 x 3/16 Binding Hd. (2)		440M	440M	Swivel Roller Assembly (rear)
A542	824S	—	Screw, 6 x 3/8 Binding Hd.	A593	340	340	Screw, 10 x 1/8 M Hd.
A543	15079	—	Capacitor 161 mfd — Sabre 800	A594	431C	431C	Axle
	15076	—	Capacitor 270 mfd — Sabre 900	A595	802S	802S	Screw, 6 x 3/16 Binding Hd.
A544	302QA	302QB	Spider	A596	433B	433B	Spring, Lip, small
A545	15223	15223	Armature Assembly, Sabre 800	A597	430B	430B	Lip, Low
	15224	—	Armature Assembly, Sabre 900				
A546	441S	441S	Screw, 6 x 5/16 Fillister Hd. (2)				

\*Specify Voltage

Always Give Machine **SERIAL NUMBER** When Ordering Parts.

Order By **PART NUMBER** — Not Key Number

# SABRE 700 MOTOR WITH STANDARD ASSEMBLY

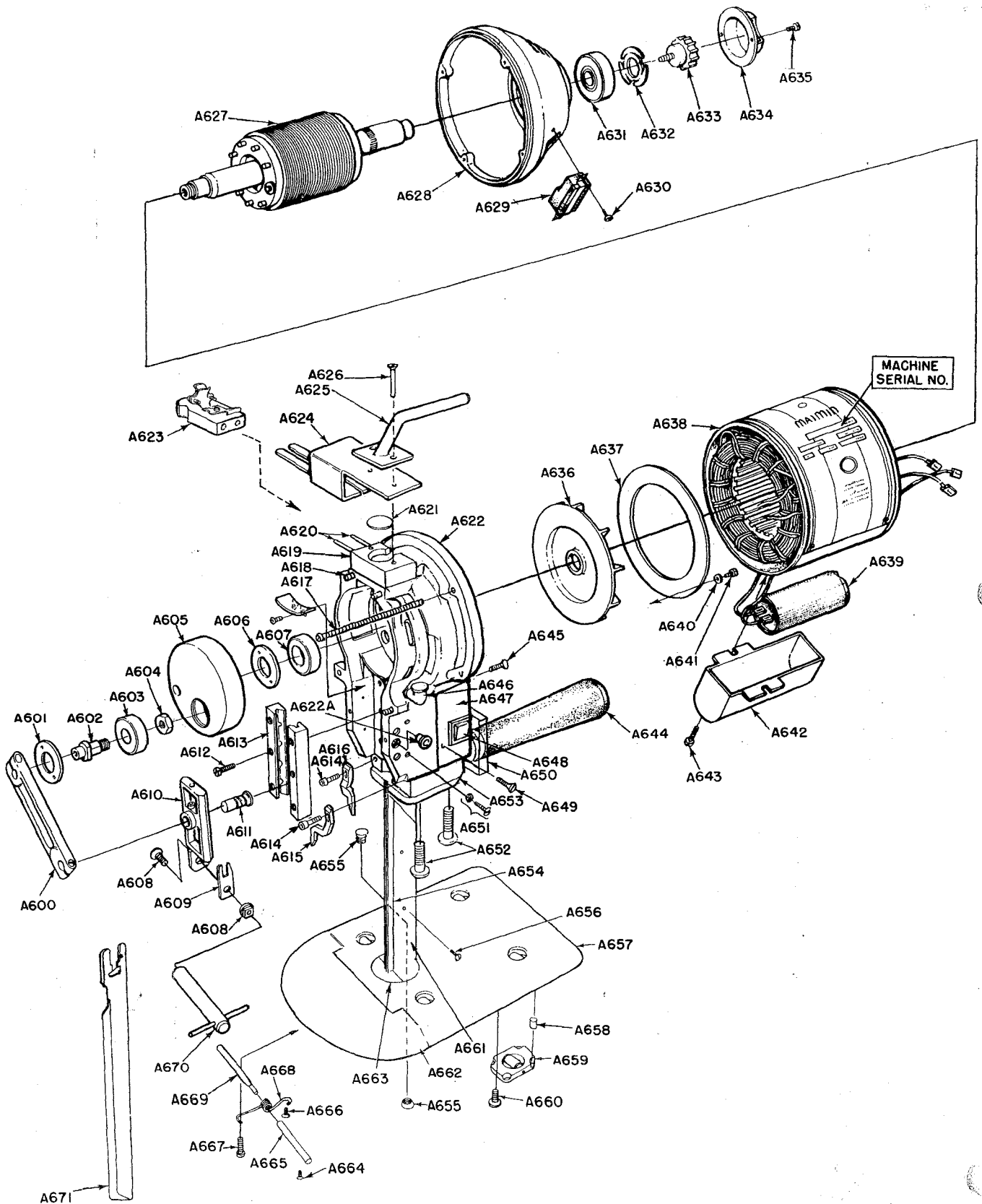



# PARTS LIST 3

KEY NO.	PART NO.		DESCRIPTION	KEY NO.	PART NO.		DESCRIPTION
	1	3			1	3	
A600	412A	412A	Connecting Rod — H	A640	438W	438W	Washer
	412B	412B	Connecting Rod — M	A641	802S	802S	Screw, 6 x 3/16 Binding Hd. (4)
	412C	412C	Connecting Rod — L	A642	15084	—	Capacitor Cover
	412D	412D	Connecting Rod — LI	A643	1187	—	Screw, 10 x 3/8 Fillister Hd. (2)
A601	413W	413W	Bearing Lock	A644	464B	464B	Tapered Handle only
A602	415	415	Crank Pin		464P	464P	Curved Handle with Bushing
A603	414	414	Crank Bearing	A645	441S	441S	Screw, 6 x 5/16 Fillister Hd (2)
A604	415N	415N	Crank Nut	A646	402BD	402BD	Oil Cup
A605	413BX	413LX	Crank — H — w/413W, 414, 415	A647	466	466	Cover, Switch
	413CX	413MX	Crank — M — w/413W, 414, 415	A648	443	443A	Switch, Rocker
	413DX	413NX	Crank — L — w/413W, 414, 415	A649	818S	818S	Screw, 6 x 1/4 Flat Hd.
	—	413VA	Screw, 1/4 x 1/4 Flat Pt. Soc. Set	A650	464R	464R	Shield
	—	413VB	Screw, 10 x 3/16 Flat Pt. Soc. Set	A651	410	410	Screw, 8 x 1/2 Fillister Hd. (2)
A606	404C	404C	Bearing Lock		410N	410N	Nut (2)
A607	403	403	Bearing #203	A652	425	425	Bolt, 3/8 x 1 Button Hd. (3)
A608	416	416	Knife Bolt & Nut	A653	464C	464C	Handle Block
A609	411A	411A	T-Slot Lock	A654	428B	428B	Insert for Standard — 8"
A610	411	411	Crosshead w/411P		428C	428C	Insert for Standard — 7"
A611	411P	411P	Wrist Pin		428D	428D	Insert for Standard — 6"
A612	409A	409A	Screw, 8 x 3/4 Fillister Hd. (6)		428E	428E	Insert for Standard — 5"
A613	409C	409C	Gibbs, pair	A655	435	435	Cone Lock & Nut
A614	23226	23226	Screw, 6 x 1/4 Socket Hd. (2)	A656	428S	428S	Insert Screw
A615	23151	23151	Cam, Right	A657	429	429	Baseplate w/Rollers & Lip
A616	23152	23152	Cam, Left		429A	429A	Small Baseplate w/Rollers & Lip
A617	419X	419E	Bolt, Motor (4)	A658	436K	436K	Rubber Cushion
A618	23230	23230	Screw, 10 x 7/8 Flat Pt. Soc. Set (3)		436L	436L	Rubber Cushion, Small Baseplate
A619	405	405A	Terminal Block with Pins	A659	436	436	Roller Carrier Assembly
A620	406	406A	Terminal Pin (2,3)		436A	436A	Roller Carrier, Small Baseplate
A621	405F	405B	Fibre Cover		436B	436B	Roller Carrier Cover for 436A
A622	402ED	402EE	Front Housing w/23230 (3)	A660	436S	436S	Screw, Roller Carrier (8)
A622A	402BG	402BG	Tapered Plug #7-S		436T	436T	Screw, Roller Carrier, Small Baseplate (8)
A623	458B	458A	Current Connector	A661	424B	424B	Standard — 8"
A624	458K	458M	Ground Shield		424C	424C	Standard — 7"
A625	407D	407D	Top Handle		424D	424D	Standard — 6"
A626	408	—	Screw, 8 x 1-1/8 Flat Hd. (2)		424E	424E	Standard — 5"
	—	408A	Screw, 8 x 1-3/4 Flat Hd. (2)	A662	430	430	Lip
A627	15115	15115	Armature, Sabre 700		430A	430A	Lip, Small Baseplate
A628	302L	302M	Back Housing	A663	426A	426A	Throat Plate 5" — 8"
A629	365B	—	Relay, Sabre 700, 668		426E	426E	V Throat Plate 5" — 8"
	366	—	Relay Bracket		426V	426V	V Throat Plate w/Nest
A630	441S	—	Screw, 6 x 5/16 Fillister Hd. (2)		427	427	Screw, 10 x 7/16 Flat Hd. (6)
A631	403	403	Bearing #203		427N	427N	Nest
A632	404D	404D	Loading Spring	A664	436S	436S	Screw, 10 x 5/32 M. Hd. (2)
A633	422B	422M	Back Knob	A665	431B	431B	Shaft, Short
A634	422E	422E	Knob Cover	A666	802S	802S	Screw, 6 x 3/16 Binding Hd.
A635	434	434	Screw, 6 x 3/16 Round Hd. (2)	A667	802S	802S	Screw, 6 x 3/16 Binding Hd.
A636	400FB	400FB	Fan XX	A668	433B	433B	Spring, Lip, small
A637	400FD	400FD	Fan Washer XX	A669	431A	431A	Shaft, Long
A638	15105	15201	Field, Sabre 700, 60 HZ*	A670	457	457	Knife Key
	15207	15201	Field, Sabre 700, 50 HZ*	A671			Blade (see back cover)
A639	15078	—	Capacitor, 216 mfd.				

\*Specify Voltage

Always Give Machine **SERIAL NUMBER** When Ordering Parts.  
Order By **PART NUMBER** — Not Key Number

# BLADES AVAILABLE

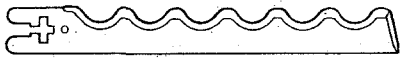
Shape & Application	Grade	Quantity	Size & Part Number						
			5"	6"	7"	8"	9"	11"	14"
<b>REGULAR</b>  For general purpose cutting	BK	Dozen	30011	30012	30013	30014	30015	—	—
	ZK	Each Dozen	30042 30043	30044 30045	30046 30047	30048 30049	30050 30051	— —	— —
<b>LONG</b>  For hard or loosely woven materials, and general purpose cutting	ZKL	Each Dozen	30082 30083	30084 30085	30086 30087	30088 30089	30090 30091	30092 30093	30094 30095
	TK	Each Dozen	30342 30343	30344 30345	30346 30347	30348 30349	30350 30351	30352 30353	30354 30355
<b>TEFLON COATED</b>  For synthetics	ZKL	Each Dozen	— —	30100 30101	— —	30102 30103	30104 30105	— —	— —
<b>WAVE</b>  For synthetics and plastics	BK	Each Dozen	30152 30153	30154 30155	— —	30158 30159	— —	— —	— —
	ZK	Each Dozen	30172 30173	30174 30175	30176 30177	30178 30179	— —	— —	— —

Note: There is a different part number for single blades and boxes of one dozen (12).  
**PLEASE ORDER BY PART NUMBER**

## H. MAIMIN CO., INC.

P.O. BOX 549 — ROUTE 341, KENT, CONNECTICUT 06757, U.S.A.